



NeXtrac[®] Merchandising Systems





Also available in Gridwall.



Portable Gondola

NeXtrac® Portable Gondolas put your merchandise where your customers are. Lockable wheels keep merchandise in place, yet allow for instant mobility if needed. Use as a stand-alone display, make runs with 2 or more units, or seamlessly integrate into your checkout queue.

Features & Benefits:

- Large locking casters for mobility.
- One-inch slat spacing allows more merchandise per square foot.
- Modular design can be used stand-alone, in runs, or integrated into your checkout queue.
- Up to 600 lbs. load capacity.

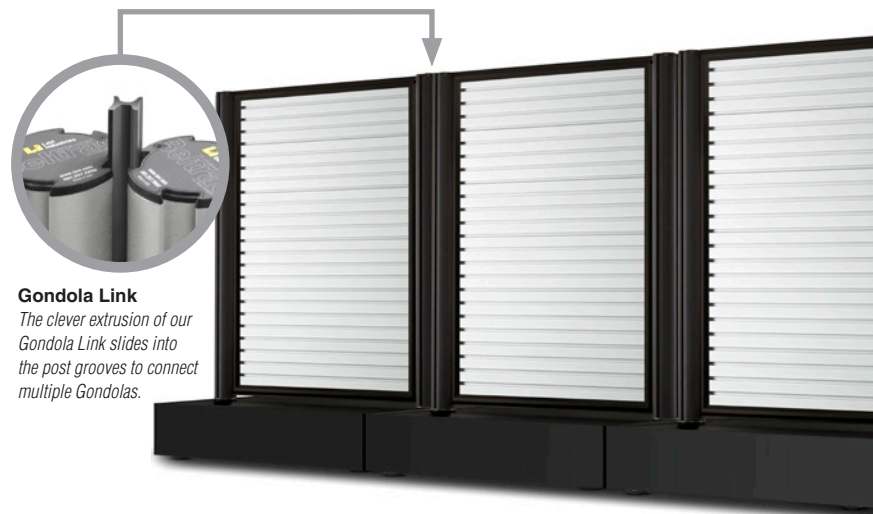

Gondola Link
The clever extrusion of our Gondola Link slides into the post grooves to connect multiple Gondolas.

SPECIFICATIONS

Portable Gondola

New Product!	
GONDOLA LINK	
Part Number	Description
80-PGL36	Links two Gondolas

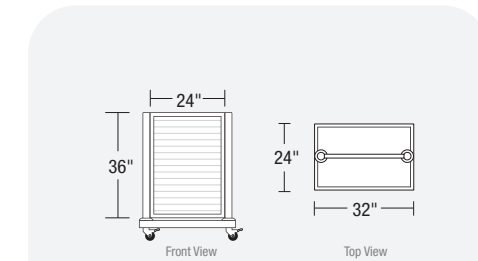

PORTABLE GONDOLA, 32L x 24W x 36H					
Part Number	Base color	Post/Frame Color	Panel Color	Wt. (in lbs.)	
50-PG2436/GY-MB/MB	Gray	Black	Black	63	
50-PG2436/GY-MB/MB/SA	Gray	Black	Satin	63	
50-PG2436/GY-MB/SA	Gray	Satin	Satin	63	
50-PG2436/MB-MB/MB	Black	Black	Black	63	
50-PG2436/MB-MB/MB/SA	Black	Black	Satin	63	
50-PG2436/MB-MB/SA	Black	Satin	Satin	63	

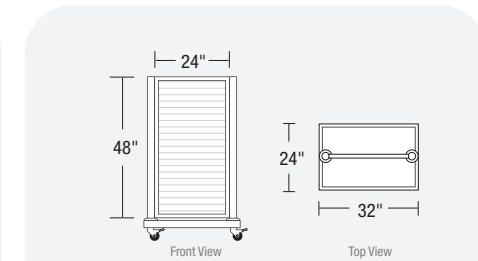

PORTABLE GONDOLA, 32L x 24W x 48H					
Part Number	Base color	Post/Frame Color	Panel Color	Wt. (in lbs.)	
50-PG2448/GY-MB/MB	Gray	Black	Black	call	
50-PG2448/GY-MB/MB/SA	Gray	Black	Satin	call	
50-PG2448/GY-MB/SA	Gray	Satin	Satin	call	
50-PG2448/MB-MB/MB	Black	Black	Black	call	
50-PG2448/MB-MB/MB/SA	Black	Black	Satin	call	
50-PG2448/MB-MB/SA	Black	Satin	Satin	call	

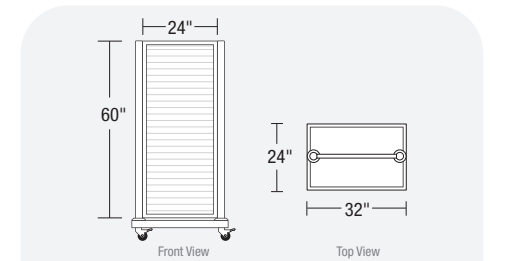

PORTABLE GONDOLA, 32L x 24W x 60H					
Part Number	Base color	Post/Frame Color	Panel Color	Wt. (in lbs.)	
50-PG2460/GY-MB/MB	Gray	Black	Black	call	
50-PG2460/GY-MB/MB/SA	Gray	Black	Satin	call	
50-PG2460/GY-MB/SA	Gray	Satin	Satin	call	
50-PG2460/MB-MB/MB	Black	Black	Black	call	
50-PG2460/MB-MB/MB/SA	Black	Black	Satin	call	
50-PG2460/MB-MB/SA	Black	Satin	Satin	call	

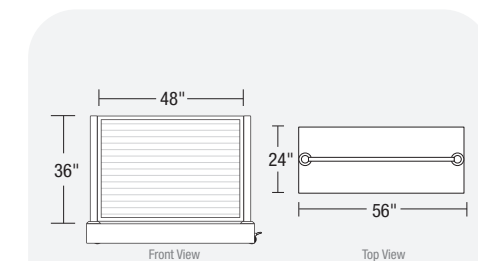

PORTABLE GONDOLA, 56L x 24W x 36H					
Part Number	Base color	Post/Frame Color	Panel Color	Wt. (in lbs.)	
50-PG4836/MB-MB/MB	Black	Black	Black	85	
50-PG4836/MB-MB/MB/SA	Black	Black	Satin	85	
50-PG4836/MB-MB/SA	Black	Satin	Satin	85	

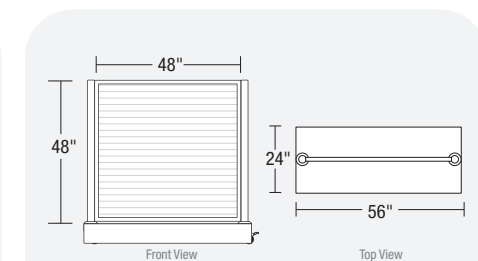

PORTABLE GONDOLA, 56L x 24W x 48H					
Part Number	Base color	Post/Frame Color	Panel Color	Wt. (in lbs.)	
50-PG4848/MB-MB/MB	Black	Black	Black	call	
50-PG4848/MB-MB/MB/SA	Black	Black	Satin	call	
50-PG4848/MB-MB/SA	Black	Satin	Satin	call	

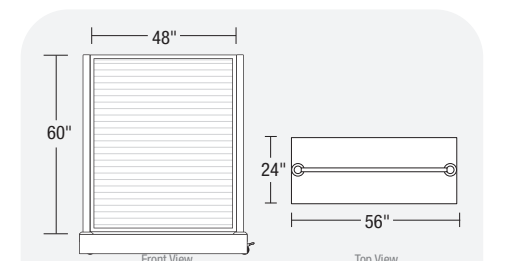

PORTABLE GONDOLA, 56L x 24W x 60H					
Part Number	Base color	Post/Frame Color	Panel Color	Wt. (in lbs.)	
50-PG4860/MB-MB/MB	Black	Black	Black	call	
50-PG4860/MB-MB/MB/SA	Black	Black	Satin	call	
50-PG4860/MB-MB/SA	Black	Satin	Satin	call	

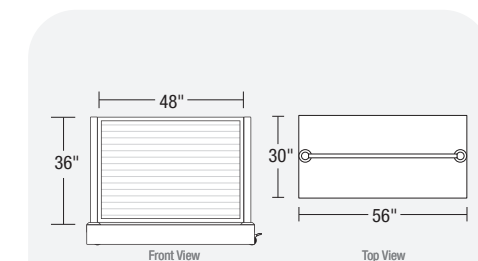

PORTABLE GONDOLA, 56L x 30W x 36H					
Part Number	Base color	Post/Frame Color	Panel Color	Wt. (in lbs.)	
50-PG4836W/MB-MB/MB	Black	Black	Black	97	
50-PG4836W/MB-MB/MB/SA	Black	Black	Satin	97	
50-PG4836W/MB-MB/SA	Black	Satin	Satin	97	

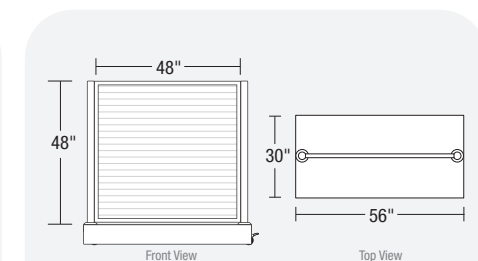

PORTABLE GONDOLA, 56L x 30W x 48H					
Part Number	Base color	Post/Frame Color	Panel Color	Wt. (in lbs.)	
50-PG4848W/MB-MB/MB	Black	Black	Black	call	
50-PG4848W/MB-MB/MB/SA	Black	Black	Satin	call	
50-PG4848W/MB-MB/SA	Black	Satin	Satin	call	

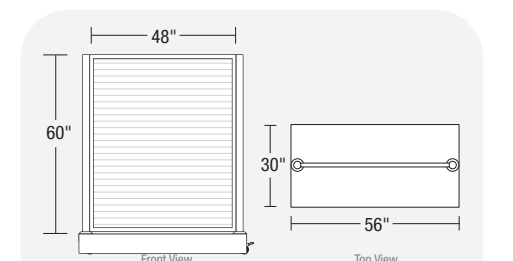

PORTABLE GONDOLA, 56L x 30W x 60H					
Part Number	Base color	Post/Frame Color	Panel Color	Wt. (in lbs.)	
50-PG4860W/MB-MB/MB	Black	Black	Black	call	
50-PG4860W/MB-MB/MB/SA	Black	Black	Satin	call	
50-PG4860W/MB-MB/SA	Black	Satin	Satin	call	



Mobile Merchandiser

Modular, flexible design puts impulse merchandise wherever your customers are.

Features & Benefits:

- Flexible design: Use with our slatwall, slat grid, or standard slot rail.
- Slim, double-sided design maximizes sales per square foot.
- Quickly connect multiple units together to form long-runs.
- Locking wheels keeps merchandise in place.



SPECIFICATIONS

Mobile Merchandiser

Simply slide the NeXtrac Gondola Link into the dovetail extrusions on adjacent units to connect mobile units.



GONDOLA LINK	
Part Number	Description
80-PGL36	Links two units

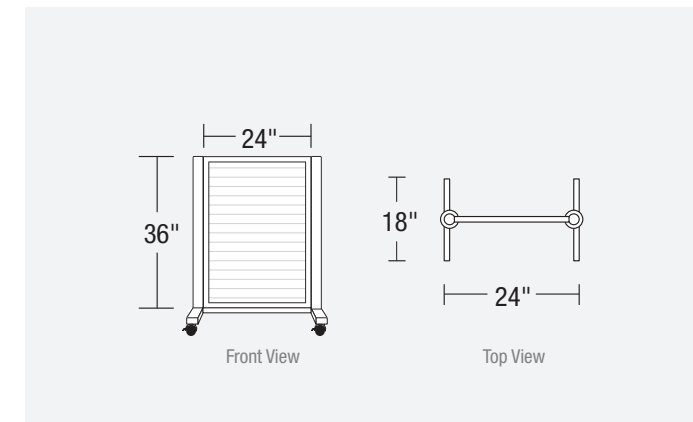

MOBILE MERCHANDISER, 24L x 36H x 18W				
Part Number	Base color	Post/Frame Color	Panel Color	Wt. [in lbs.]
50-PGH2436/MB/MB/MB	Black	Black	Black	36 lb
50-PGH2436/MB/SA	Black	Satin	Satin	36 lb

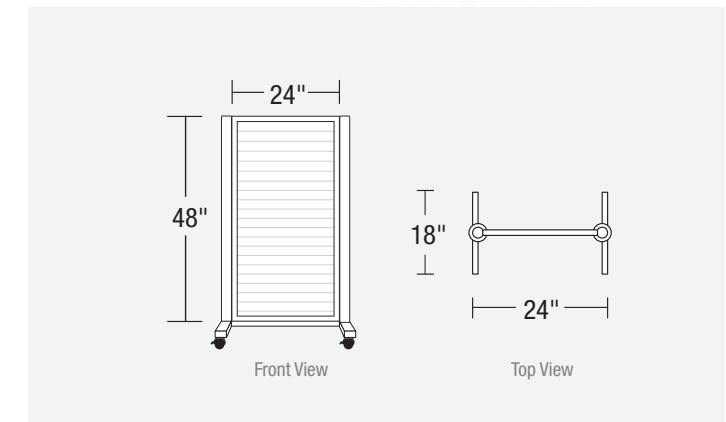

MOBILE MERCHANDISER, 24L x 48H x 18W				
Part Number	Base color	Post/Frame Color	Panel Color	Wt. [in lbs.]
50-PGH2448/MB/MB/MB	Black	Black	Black	44 lb
50-PGH2448/MB/SA	Black	Satin	Satin	44 lb

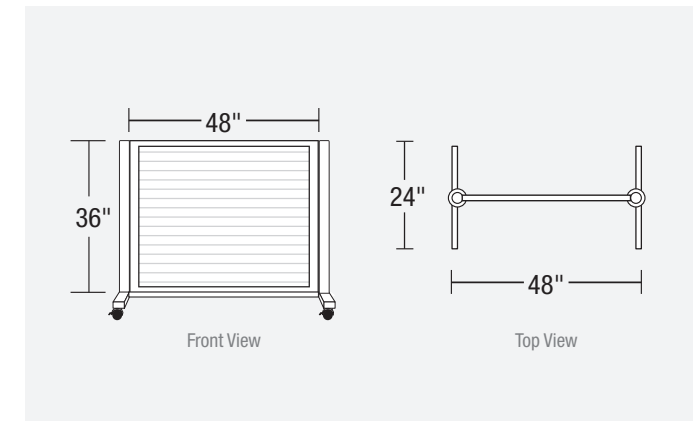

MOBILE MERCHANDISER, 48L x 36H x 24W				
Part Number	Base color	Post/Frame Color	Panel Color	Wt. [in lbs.]
50-PGH4836/MB/MB/MB	Black	Black	Black	55 lb
50-PGH4836/MB/SA	Black	Satin	Satin	55 lb

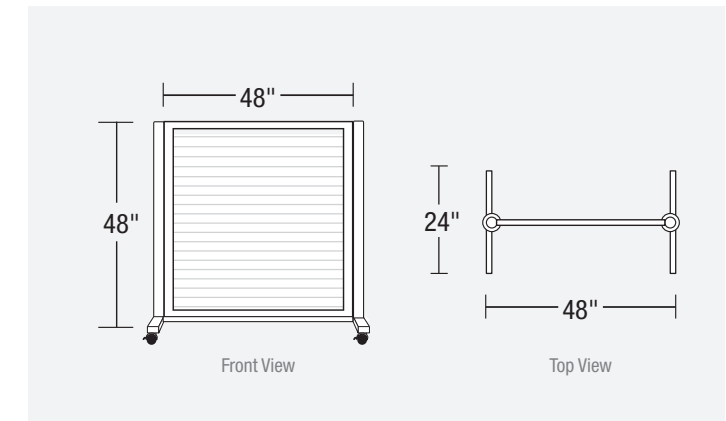

MOBILE MERCHANDISER, 48L x 48H x 24W				
Part Number	Base color	Post/Frame Color	Panel Color	Wt. [in lbs.]
50-PGH4848/MB/MB/MB	Black	Black	Black	66 lb
50-PGH4848/MB/SA	Black	Satin	Satin	66 lb



SPECIFICATIONS

Slatwall Panel

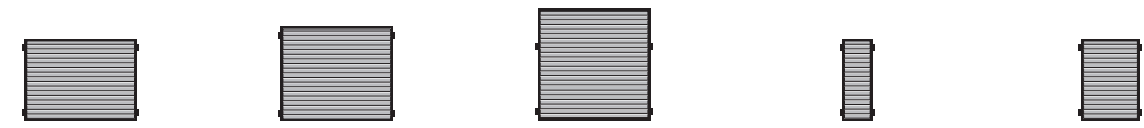

	50-HSW1004	50-HSW1007	50-HSW1005	50-HSW1025	50-HSW1002
Size	48" x 36" Slatwall	48" x 42" Slatwall	48" x 48" Slatwall	10" x 48" Slatwall	24" x 36" Half-size Framed Slatwall
Frame Finish	Satin or Matte Black	Satin or Matte Black	Satin or Matte Black	Satin or Matte Black	Satin or Matte Black
Slatwall Finish	Satin, Matte Black	Satin, Matte Black	Satin, Matte Black	Satin, Matte Black	Satin, Matte Black
Fits Post [height]	50-3002M [40"]	50-30048M [48"]	50-30052M [52"]	50-3002M [40"]	50-3002M [40"]
Load Capacity	400 lbs. maximum	400 lbs. maximum	400 lbs. maximum	400 lbs. maximum	200 lbs. maximum

Merchandising Posts



	BELTRAC® 3002	BELTRAC® 30046	BELTRAC® 30052	BELTRAC® 3005	BELTRAC® 3006	BELTRAC® 3007	BELTRAC® 3008
Height	40 inches	46 inches	52 inches	66 inches	72 inches	84 inches	96 inches
Weight (with Standard Base)	25.5 - 28 lbs.	26.5 - 29 lbs.	27.5 - 30 lbs.	29.5 - 32 lbs.	31.5 - 34 lbs.	35.5 - 38 lbs.	42.5 - 45 lbs.
Finish	Satin Aluminum or Wrinkle Black	Satin Aluminum or Wrinkle Black	Satin Aluminum or Wrinkle Black	Satin Aluminum or Wrinkle Black	Satin Aluminum or Wrinkle Black	Satin Aluminum or Wrinkle Black	Satin Aluminum or Wrinkle Black
Post Diameter	2 ¾ inches	2 ¾ inches	2 ¾ inches	2 ¾ inches	2 ¾ inches	2 ¾ inches	2 ¾ inches
Post Construction	Extruded Aluminum	Extruded Aluminum	Extruded Aluminum	Extruded Aluminum	Extruded Aluminum	Extruded Aluminum	Extruded Aluminum
Base Connection	Aluminum Insert	Aluminum Insert	Aluminum Insert	Aluminum Insert	Aluminum Insert	Aluminum Insert	Aluminum Insert
Recommended Base Options & Measurements	Standard: 14" Heavy: 14"	Standard: 14" Heavy: 14"	Standard: 14" Heavy: 14"	Standard: 14" Heavy: 14"	Standard: 14" Heavy: 14"	Standard: 14" Heavy: 14"	Standard: 14" Heavy: 14"
Rubberized Base	Standard	Standard	Standard	Standard	Standard	Standard	Standard

Slatwall Panel & Merchandising Posts

One-inch aluminum slatwall provides strength and flexibility.

Features & Benefits:

- Increases impulse-buying at checkout.
- Designed to work seamlessly with new or existing Beltrac® 3000s.
- Provides an engaging experience for customers in line, reducing their perceived wait time.
- Effectively uses retail space, maximizing sales per square foot.
- Extremely flexible and versatile, components work together seamlessly for endless options.
- Modular expandability works within any budget, large or small.

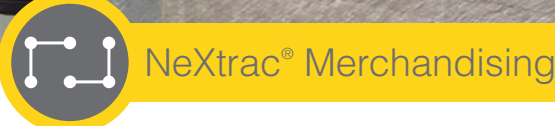

SPECIFICATIONS

Slatwall Shelves

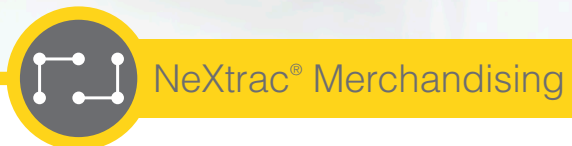
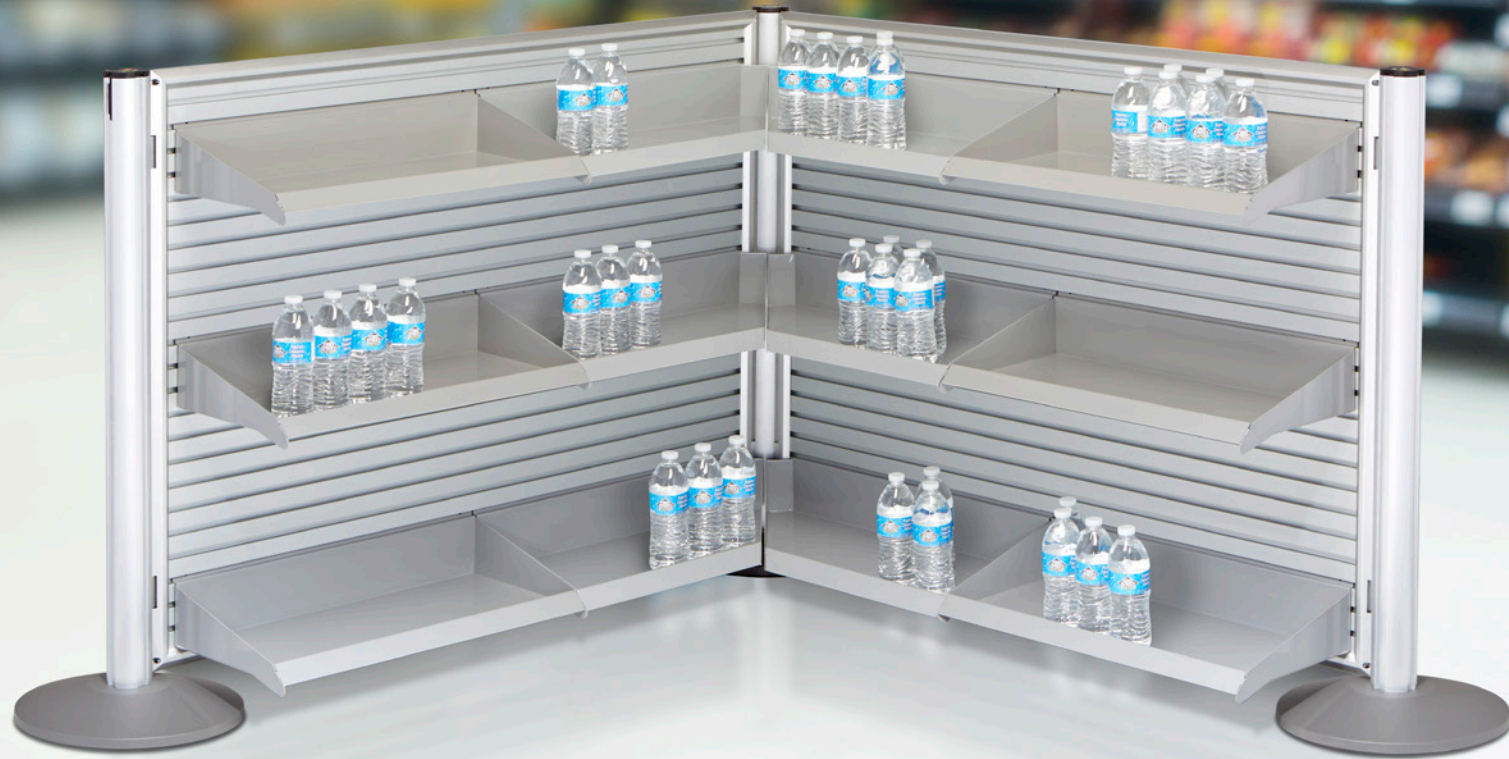



Slatwall Shelves

Showcase your merchandise with genuine NeXtrac shelves.

Features & Benefits:

- Captured shelves keep merchandise in place.
- Maximize your merchandising opportunities by displaying last-minute "reminder" items the customer may have forgotten to place in their cart.
- Clearly displayed merchandise increases impulse sales.
- 10-inch deep corner shelves allow for merchandising on inside corners.

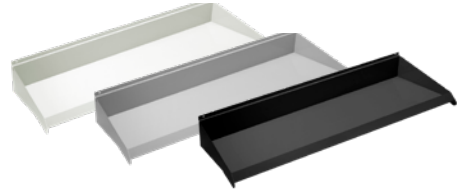
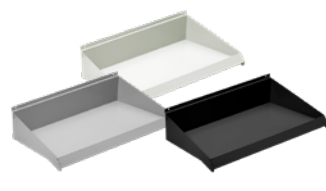
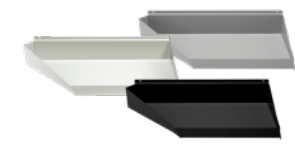
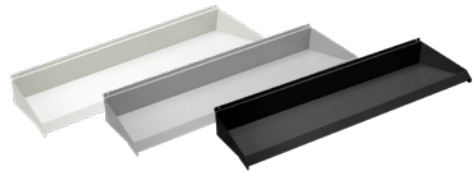
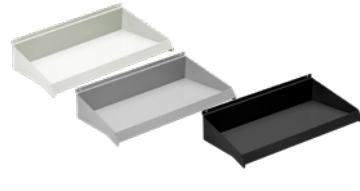
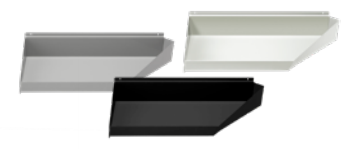
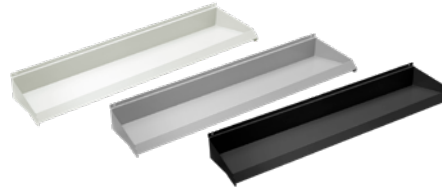
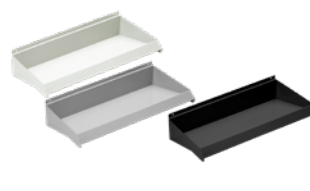

STANDARD SHELVES		SPECIALTY SHELVES		
				
Part Number	26-SWS1248/XX*	26-SWS1224/XX*	Part Number	26-SWS1024/XX*/RC
Description	Long 12-inch deep shelf	Short 12-inch deep shelf	Description	Right Corner 10-inch deep shelf
Dimensions	48" wide by 12" deep	24" wide by 12" deep	Dimensions	24" x 10" deep
Available Colors	Gray (GY), Matte Black (MB), White (LW)	Gray (GY), Matte Black (MB), White (LW)	Available Colors	Gray (GY), Matte Black (MB), White (LW)
				
Part Number	26-SWS1048/XX*	26-SWS1024/XX*	Part Number	26-SWS1024/XX*/LC
Description	Long 10-inch deep shelf	Short 10-inch deep shelf	Description	Left Corner 10-inch deep shelf
Dimensions	48" wide by 10" deep	24" wide by 10" deep	Dimensions	24" x 10" deep
Available Colors	Gray (GY), Matte Black (MB), White (LW)	Gray (GY), Matte Black (MB), White (LW)	Available Colors	Gray (GY), Matte Black (MB), White (LW)
				
Part Number	26-SWS0848/XX*	26-SWS0824/XX*	Part Number	26-SWS1048/ADJ/XX*
Description	Long 8-inch deep shelf	Short 8-inch deep shelf	Description	Adjustable shelf with 5-position tilt
Dimensions	48" wide by 8" deep	24" wide by 8" deep	Dimensions	48" x 10" deep
Available Colors	Gray (GY), Matte Black (MB), White (LW)	Gray (GY), Matte Black (MB), White (LW)	Available Colors	Gray (GY)

*XX = COLOR DESIGNATION

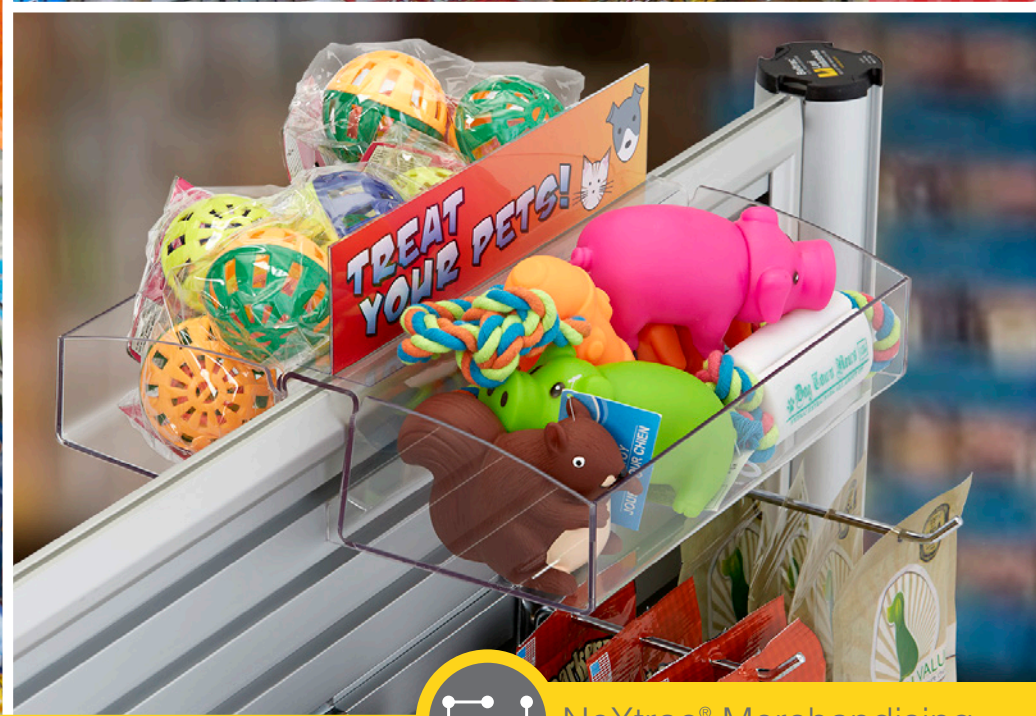

Baskets, Hooks & Trays

Increase impulse sales with clearly-displayed merchandise.

Features & Benefits:

Our assortment of hooks and baskets allow for a variety of merchandising solutions. Their standardized design will also allow them to be incorporated into your existing fixtures.



SPECIFICATIONS

Baskets, Hooks & Trays

STANDARD HOOKS



Product Description	2-inch hooks	4-inch hooks	6-inch hooks	8-inch hooks
Part Numbers	808811	809049	808685	807235
Colors Available	Black or Chrome	Black or Chrome	Black or Chrome	Black or Chrome

SCANNER HOOKS



Product Description	2-inch Scanner Hooks	4-inch Scanner Hooks	6-inch Scanner Hooks	8-inch Scanner Hooks
Part Numbers	820020/CL/SET	820040/CL/SET	820060/CL/SET	820080/CL/SET
Colors Available	Black or Chrome	Black or Chrome	Black or Chrome	Black or Chrome

BASKETS



Product Description	Small Baskets	Large Baskets	Endless Wire Basket
Part Number[s]	809679 (Black) or 809680 (Chrome)	806772 (Black) or 808681 (Chrome)	26-1248E/CL
Dimensions	L=12", W=6", D=6"	L=24", W=12", D=4"	L=48", W=12", D=8"
Colors Available	Black or Chrome	Black or Chrome	Chrome (only)
Accessories			Shelf Dividers: 26-1201SI/CL

DUAL BIN SLATWALL TOPPER WITH SIGN HOLDER

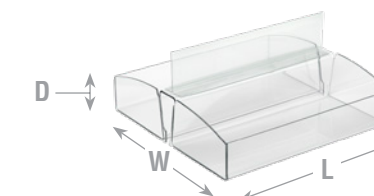

Product Description	Clear Acrylic Dual-bin Slatwall Topper	
Part Number	80-DBT1212-CL	
Bin Dimensions	OVERALL: L=12" W=11¼", D= 2¼"	INDIVIDUAL BINS: L=12", W=5"
Sign Holder Dimensions	L=11", D=2½"	
Material/Color	Clear Acrylic	

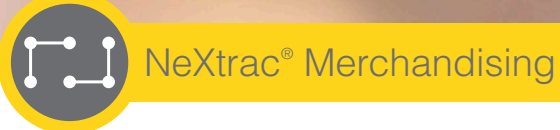

Wire Basket Endcap Kits

Easily add endcap merchandising to your NeXtrac system

Features & Benefits:

- Endcap design helps merchandise to cross-traffic or in a switchback
- Large, deep basket keeps merchandise in place
- Heavy-gauge wire withstands heavy use
- Kit contains 2 Standard Slot Extrusions, 2 Brackets per Basket, and 2 or 3 heavy-gauge Wire Baskets (Stanchion sold separately)

PART NUMBER	DESCRIPTION	COLOR	OVERALL BASKET DIMENSIONS
26-EB1/CL/2	2-Basket Kit	Chrome	25.5" wide x 7.5" high x 13.5" deep
26-EB1/CL/3	3-Basket Kit	Chrome	25.5" wide x 7.5" high x 13.5" deep
26-EB1/CL	Basket only	Chrome	25.5" wide x 7.5" high x 13.5" deep



26-EB1/CL/2

26-EB1/CL/3



Deters theft!

While the NeXtrac Cover makes it difficult for thieves to access your merchandise and is a great theft deterrent, it can't prevent theft due to the nature of its material and construction.

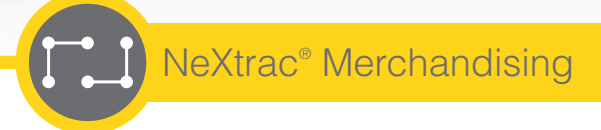

NeXtrac® Cover

Keep merchandise safe and secure during non-operating hours.

Features & Benefits:

- Works with standard 4' x 3' Slatwall panels.
- Keeps merchandise safely hidden during non-operating hours.
- Toggle cord lock makes this cover simple to install and remove.
- Durable and fire-retardant ripstop nylon.
- Folds flat easily for storage.

PART NUMBER	DESCRIPTION
60-GCV001/BK	Fits 4' x 3' panels. Made of fire-retardant black nylon.



Clip Signage for Slatwall Panels

Easily add signage or branding to the top of in-queue merchandising displays.





Features & Benefits:



- Easy to install. Just snap onto the frame and slide into position as necessary.
- Paper media can be easily changed.
- Many sizes to fit your message.
- Scratch resistant.
- Increase brand exposure to a captive audience.

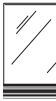

SPECIFICATIONS

Clip Signage for Slatwall Panels

					
PART NUMBER	80-1150SFH	80-1130SFV	80-1130SFH	80-1141SFV	80-1141SFH
MEDIA SIZE	7" x 5.5"	7" x 11"	11" x 7"	8.5" x 11"	11" x 8.5"
OVERALL DIMS	7" wide x 7" high x 1.5" deep	7" wide x 12.5" high x 1.5" deep	11" wide x 8.5" high x 1.5" deep	8.5" wide x 12.5" high x 1.5" deep	11" wide x 10" high x 1.5" deep
WEIGHT	.5 lbs.	1 lbs.	1 lbs.	1 lbs.	1 lbs.

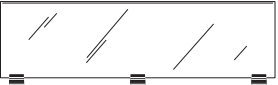
				
PART NUMBER	80-11824SFH	80-11836SFH	80-11924SFH	80-11936SFH
MEDIA SIZE	24" x 4"	36" x 4"	24" x 10"	36" x 10"
OVERALL DIMS	24" wide x 5.5" high x 1.5" deep	36" wide x 5.5" high x 1.5" deep	24" wide x 11.5" high x 1.5" deep	36" wide x 11.5" high x 1.5" deep
WEIGHT	1 lbs.	1.5 lbs.	3 lbs.	4 lbs.

Changing graphics is easy!

1. Remove the black plastic clip(s) and gently separate the edges of the acrylic holder, taking care not to open it too wide to prevent cracking.
2. Insert paper graphic and work it in between the acrylic.
3. Once graphic is positioned, replace the black plastic clips.
4. Snap the assembled sign frame onto a Hinged Frame Panel. To replace graphics, repeat as necessary.

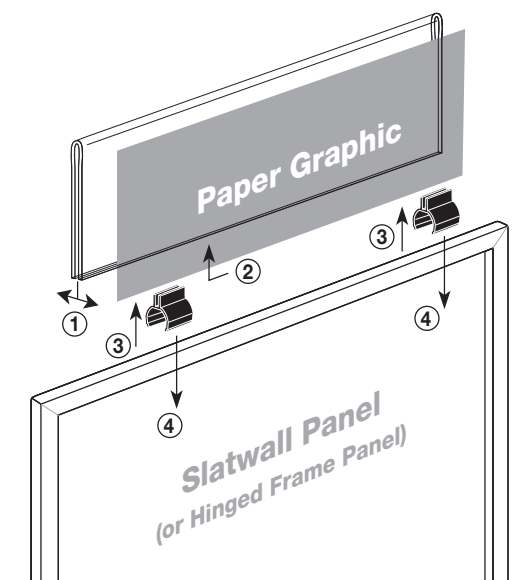



NeXtrac[®]
Merchandising
Systems

 **Lavi Industries**

27810 Avenue Hopkins, Valencia CA 91355
800.624.6225 • lavi.com

© Lavi Industries. All Rights Reserved.